

Scope

The DK90308 and DK90314 provide a communications interface between the device and PC. All necessary components for implementing the three application circuits with the user's bridge sensor are on board. This document describes the board itself and setup of the common application circuits for the DK90308 and DK90314 Evaluation kit.

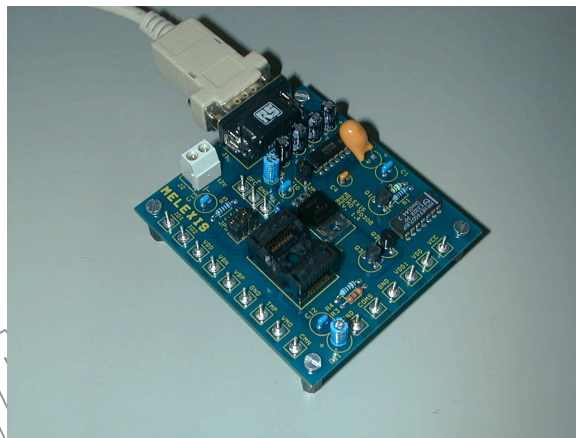

Related Products and Tools

MLX90308 Programmable Sensor Interface
MLX90314 Programmable Sensor Interface
SW90308 Software for MLX90308CCC and MLX90314AB
90308CCC90314AB UsersManual.pdf
WWW.MELEXIS.COM

Applications

Absolute Voltage Output Mode : The device uses an external FET to regulate the supply voltage. The supply voltage is supplied from J2 thru JP3 to VDD1, then the device regulates +5V on VDD using the onboard FET giving a stable output over varied supply voltage.

Ratiometric Voltage Output Mode: In this application the output follows the supply voltage; this is used when the device output is tied to an A/D converter sharing the same supply and ground reference. A 4.5V to 5.2V supply voltage is supplied thru VDD and VDD1 tied together. **JP3 MUST BE OPEN FOR THIS MODE** to avoid permanent damage to the chip.

Current Output Mode: In Current Mode the device supplies a 4 to 20mA current range for use as a 2-wire analog sensor. VDD is regulated by the onboard FET from the supply (7V to 35V) thru VDD1. JP3 must be open to separate the interface circuit supply thru J2 from the device current supply thru VDD1. The device supply ground must be floating with respect to the interface circuit ground. **DO NOT CONNECT CMN to GND.**

The DK90308 and DK90314 can also be used to communicate with the MLX90308 and MLX90314 in custom external circuits.

For more information about the MLX90308 and MLX90314 consult the device datasheet.

Demoboard Layout and Jumper Settings

Component side view:

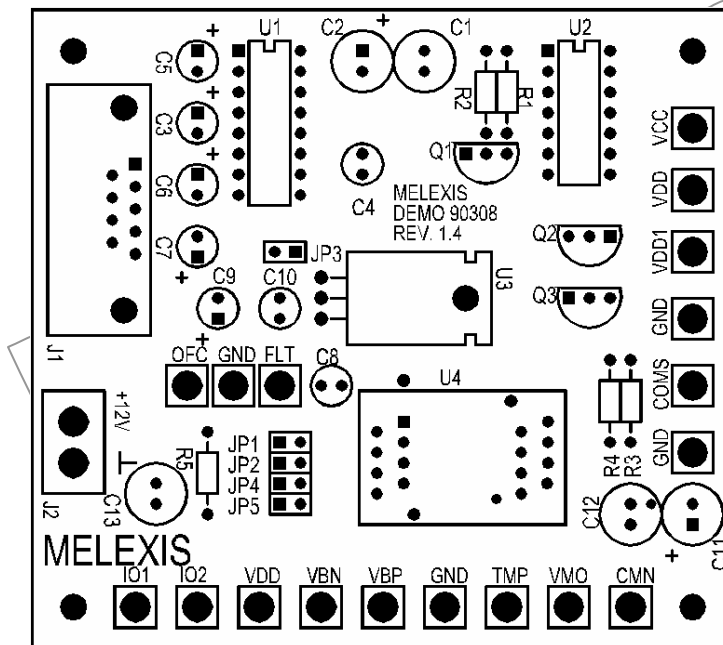

Test Point	Function	SO16 DUT Pin Number	Jumper	Function
IO1	Bidirectional I/O	1	<p>JP3</p> <p>+12V Supply to VDD1</p> <ul style="list-style-type: none"> - Absolute Voltage Mode - Jumper shorted - Ratiometric Mode – Jumper open - VDD1 will be shorted to VDD - Current Mode – Jumper Open <p>Caution: Device may be permanently damaged if this Jumper is not set correctly.</p> <p>JP1</p> <p>JP2</p> <p>JP4</p> <p>JP5</p>	
IO2	Bidirectional I/O	2		
VDD	Regulated Supply Input	9		
VBN	Negative Bridge Input	6		
VBP	Positive Bridge Input	7		
GND	Common Power Ground	15		
TMP	Temperature Sensor Input	8		
VMO	Voltage Mode Output	12		
CMN	Current Mode Negative Return	14		
COMS	Serial Programming I/O	16		
VDD1	Unregulated Supply Input	11		
VCC	Regulated +5V Power Supply from board	-		
OFC	Offset Control Output	5		
FLT	Filter Pin	4		
J2: +12V	Power Supply +12V Terminal	-		
J2: +	Power Supply Ground Terminal	-		

Schematic

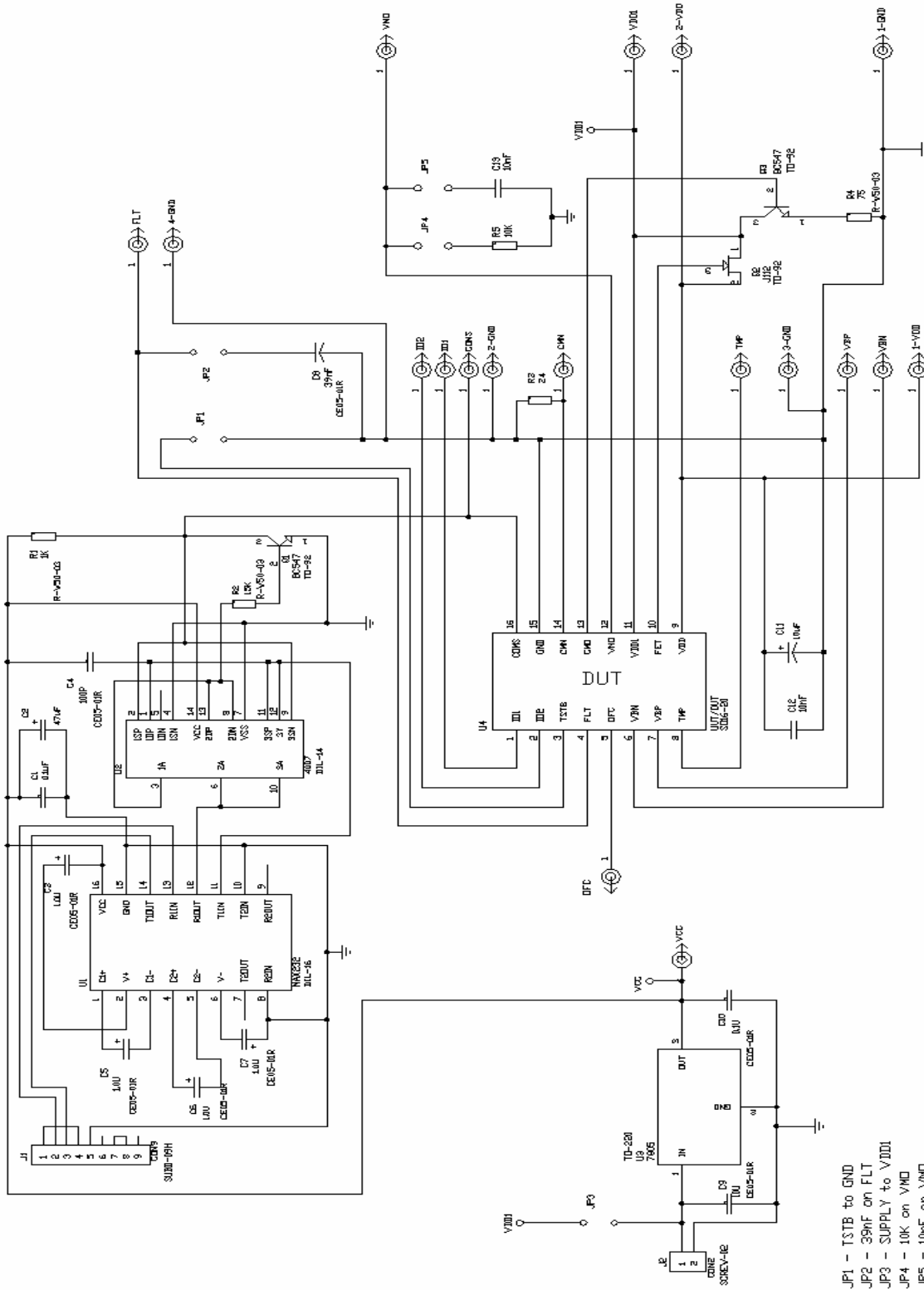

Typical Connection Schemes

Absolute Voltage Output Mode:

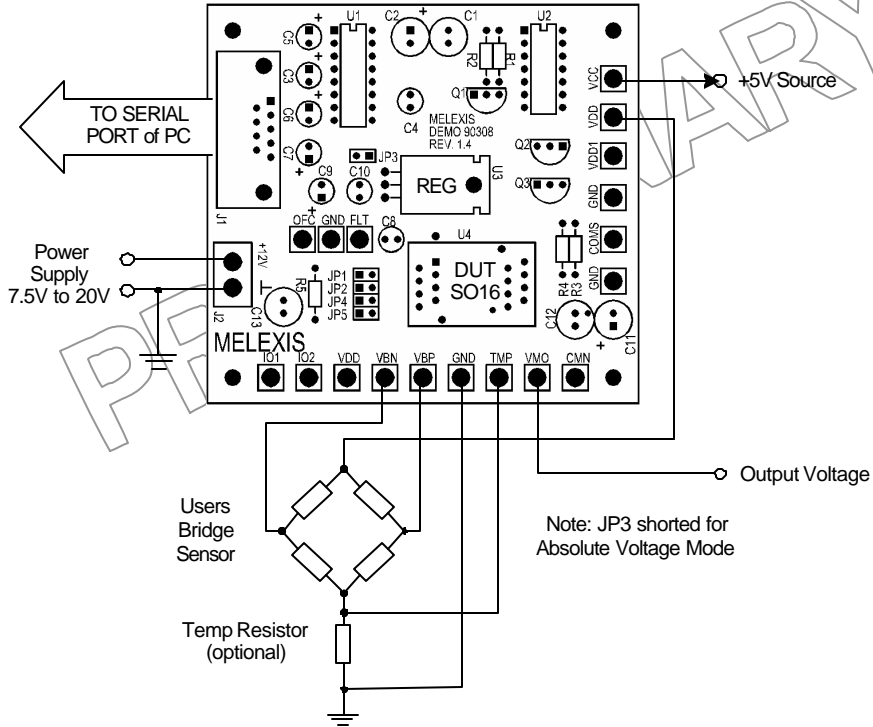

Ratiometric Voltage Output Mode:

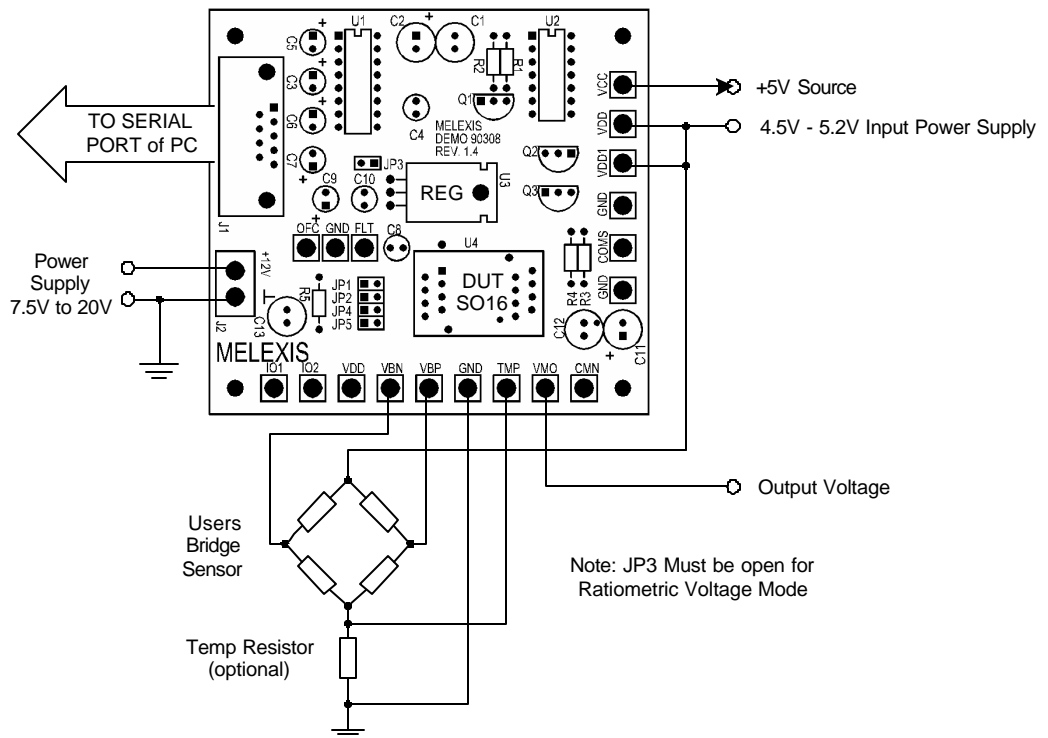

Current Output Mode:

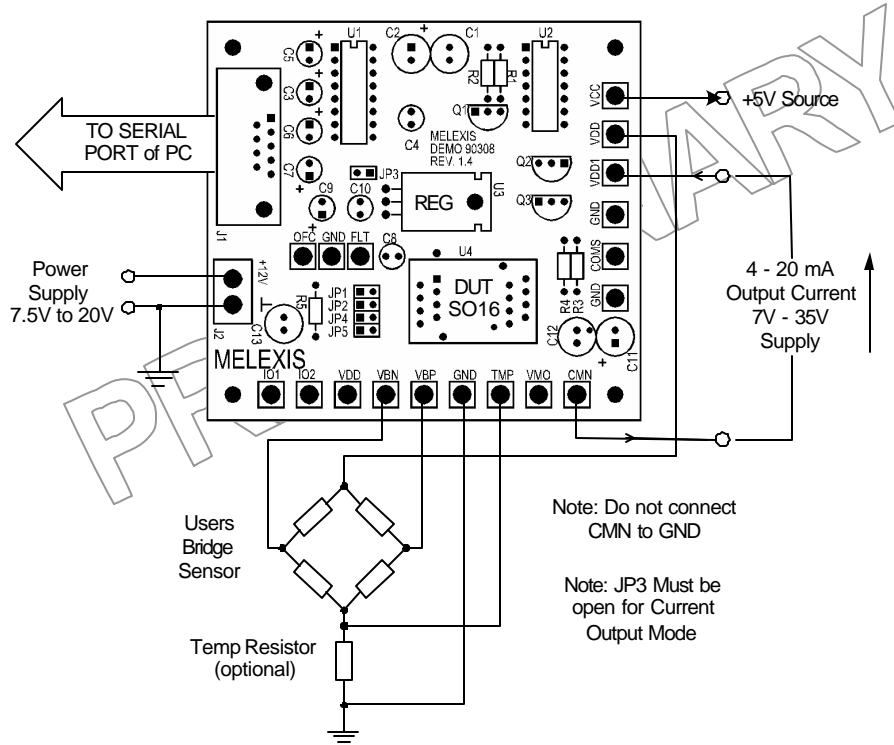

External Circuit Communication:

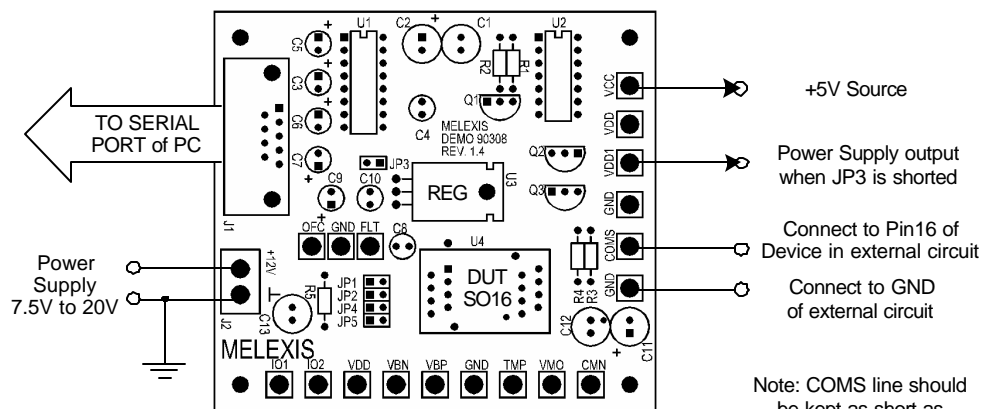

Note: This is the minimal connections necessary for communication with a device in a circuit external from the application board. The board can only connect to one device at a time therefore the local device socket U4 must be empty when connected to an external circuit. All other connections to the external circuit are subject to which output mode is required and must be determined by the user.